

03

Identification

Part No.

Drawing

M12-male
moving load
A-coding



21 03 030 1400

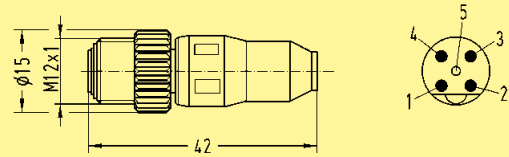

HARTING M12 T-Coupler

21 03 321 9400



Crimping tool
for M12 Crimp

09 99 000 0501



Accessories M12 Crimp

Locator

09 99 000 0531



D-Sub contacts

Part number	AWG	Tool settings
09 67 000 3x76	18	6
	20	6
	22	5
09 67 000 8x76	20, 22, 24	6
09 67 000 5x76	22, 24, 26	6

D-Sub single contacts
(500 mating cycles)

turned male contacts

AWG 22 - 18 / 0.33 - 0.82 mm² 09 67 000 3576
 AWG 24 - 20 / 0.25 - 0.52 mm² 09 67 000 8576
 AWG 26 - 22 / 0.13 - 0.33 mm² 09 67 000 5576



turned female contacts

AWG 22 - 18 / 0.33 - 0.82 mm² 09 67 000 3476
 AWG 24 - 20 / 0.25 - 0.52 mm² 09 67 000 8476
 AWG 26 - 22 / 0.13 - 0.33 mm² 09 67 000 5476

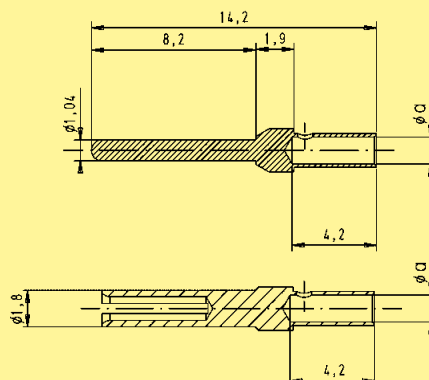

	a
AWG 22 - 18	1.34
AWG 24 - 20	1.13
AWG 26 - 22	0.88

M12
dynamometric screwdriver

Tightening torque 0.6 Nm

for M12-S SW 13 09 99 000 0382

for M12 Slim design SW 15 09 99 000 0646

for M12-L SW 17 09 99 000 0384



03
36