

THIS DRAWING IS UNPUBLISHED. RELEASED FOR PUBLICATION ,19 .
 © COPYRIGHT 19 BY AMP INCORPORATED. ALL RIGHTS RESERVED.

| LOC | | DIST | | REVISIONS | | | |
|-----|-----|-------------|----------------------|-----------|-----|------|--|
| P | LTR | DESCRIPTION | | DATE | DWN | APVD | |
| G | 14 | G | REV PER 0G3A-0176-02 | 08APR02 | JR | TM | |

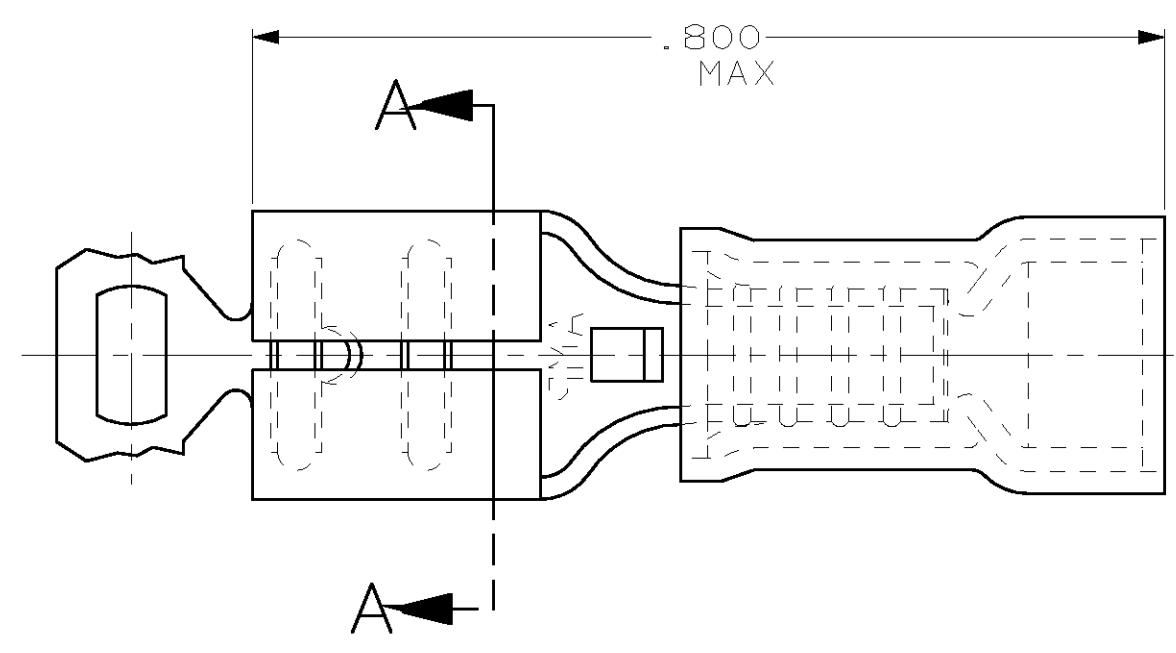

- 1. INSULATION DIA .170 MAX
- 2. FITS TAB .020 THK

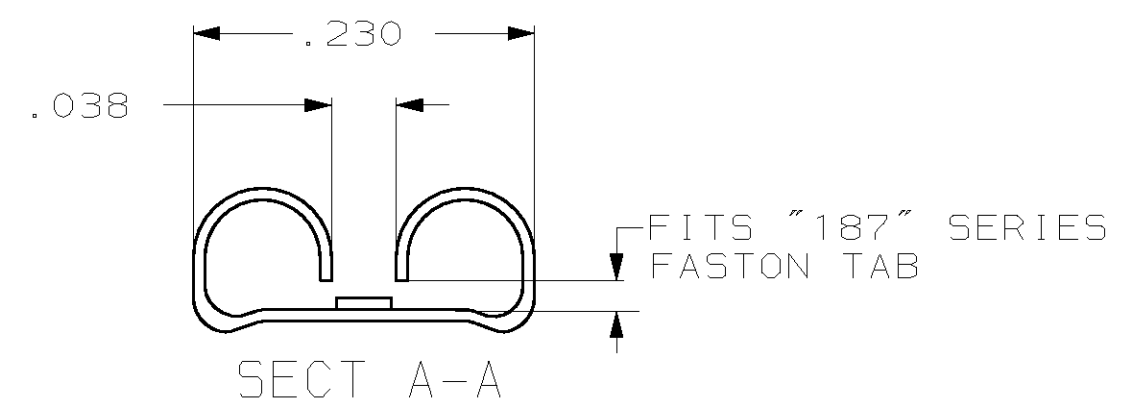
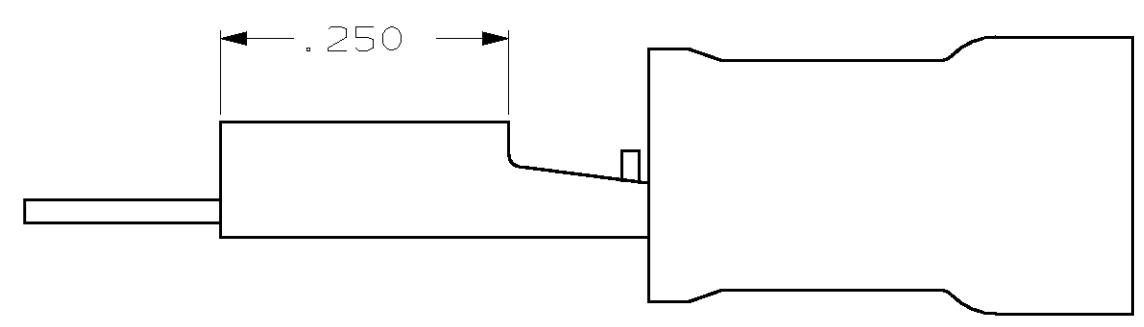

| | | |
|-----|--------------|----------|
| - | - | 640918-1 |
| QTY | PACKAGE TYPE | PART NO |

AMP INCORPORATED
CUSTOMER SERVICE SYSTEM

| | |
|--|--|
| FOR ADDITIONAL PRODUCT INFORMATION OR COPIES OF DRAWINGS AND TECHNICAL DOCUMENTS | PRODUCT INFORMATION CENTER 1-800-522-6752 |
| FOR APPLICATION TOOLING INFORMATION | TOOLING ASSISTANCE CENTER 1-800-722-1111 |
| FOR ORDER ENTRY | 1-800-526-5142 |

MAX RECOMMENDED OPERATING TEMPERATURE:
-

VOLTAGE RATING:
-

CIRCULAR MIL AREA:
-

THIS DRAWING IS A CONTROLLED DOCUMENT FOR AMP INCORPORATED. IT IS SUBJECT TO CHANGE AND THE CONTROLLING ENGINEERING ORGANIZATION SHOULD BE CONTACTED FOR THE LATEST REVISION.

| DIMENSIONS, INCHES | TOLERANCES UNLESS OTHERWISE SPECIFIED: |
|--------------------|--|
| | 0 PLC ±- |
| | 1 PLC ±- |
| | 2 PLC ±.015 |
| | 3 PLC ±- |
| | 4 PLC ANGLES ±- |

MATERIAL: BODY, BRASS .016; SLV, NYLON, COLOR, BLUE

FINISH: BODY, TIN

| | | |
|------------------|----------|-----------|
| DWN | L OLMEDA | 26 JUN 95 |
| CHK | M ELLIS | 26 JUN 95 |
| APVD | B BARE | 26 JUN 95 |
| PRODUCT SPEC | - | - |
| APPLICATION SPEC | - | - |
| WEIGHT | - | - |

CUSTOMER DRAWING

AMP AMP Incorporated
 Harrisburg, PA 17105-3608

NAME: RECEPTACLE, 187 SERIES, FASTON™, PIDG™, WIRE SIZE, 16-14 AWG

| | | |
|------|-----------|------------|
| SIZE | CAGE CODE | DRAWING NO |
| A3 | 00779 | C-640918 |

SCALE: NT5 SHEET: 1 OF 1 REV: G